

# LR Mate 200iD/7H



Max. load capacity  
at wrist: **7 kg**



Max. reach:  
**717 mm**

Controlled axes	Repeatability (mm)	Mechanical weight (kg)	Motion range (°)							Maximum speed (°/s)							J4 Moment/ Inertia (Nm/kgm <sup>2</sup> )	J5 Moment/ Inertia (Nm/kgm <sup>2</sup> )	J6 Moment/ Inertia (Nm/kgm <sup>2</sup> )
			J1	J2	J3	J4	J5	J6	E1	J1	J2	J3	J4	J5	J6	E1			
5	± 0.018*	24	360	245	420	250	720	-	-	450	380	520	545	1500	-	-	16.6/0.47	4.0/0.046 (5.5/0.15)	-

## Working range

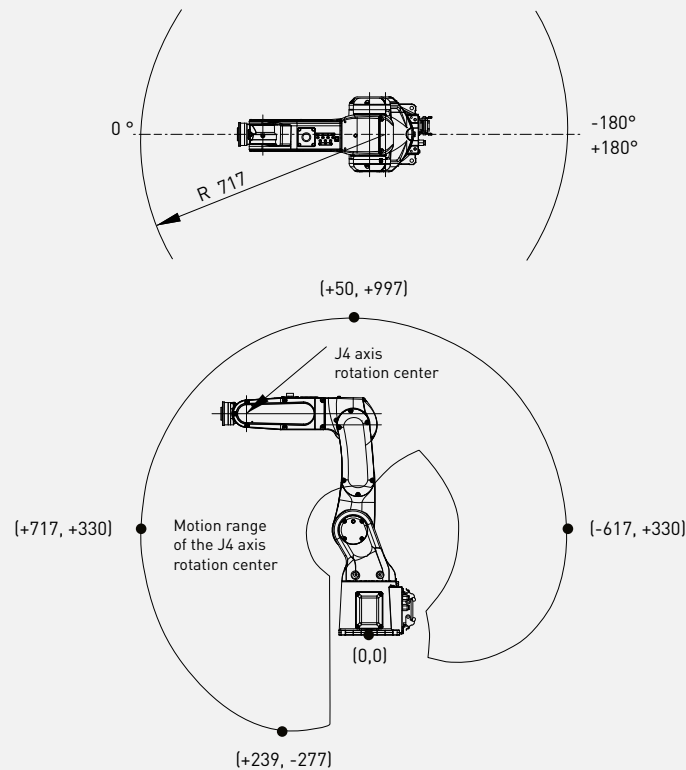

Motion range may be restricted according to the mounting angle!

## Robot

	LR Mate 200iD/7H
Robot footprint [mm]	190 x 190
Mounting position Floor	●
Mounting position Upside down	●
Mounting position Angle	●

## Controller

	R-30iB Plus
Open air cabinet	○
Mate cabinet	●
A-cabinet	-
B-cabinet	-
iPendant Touch	●

## Electrical connections

Voltage 50/60Hz 3phase [V]	-
Voltage 50/60Hz 1phase [V]	200-230
Average power consumption [kW]	0.5

## Integrated services

Integrated signals on upper arm In/Out	6/2
Integrated air supply	1

## Environment

Acoustic noise level [dB]	64.7
Ambient temperature [° C]	0-45

## Protection

Body standard/optional	IP67/IP69K
Wrist & J3 arm standard/optional	IP67/IP69K
Clean room [ISO Class 4]	-

● standard ○ on request - not available ( ) with hardware and/or software option

\*Based on IS09283