

M-20iB/25C



Max. load capacity
at wrist: **25 kg**



Max. reach:
1853 mm

Controlled axes	Pose Repeatability (mm)	Mechanical weight (kg)	Motion range (°)						Maximum speed (°/s)						J4 Moment/ Inertia (Nm/kgm ²)	J5 Moment/ Inertia (Nm/kgm ²)	J6 Moment/ Inertia (Nm/kgm ²)
			J1	J2	J3	J4	J5	J6	J1	J2	J3	J4	J5	J6			
6	± 0.023*	210	340(360)	240	303	400	290	540	205	205	260	415	415	880	51/2.2	51/2.2	31/1.2

Working range

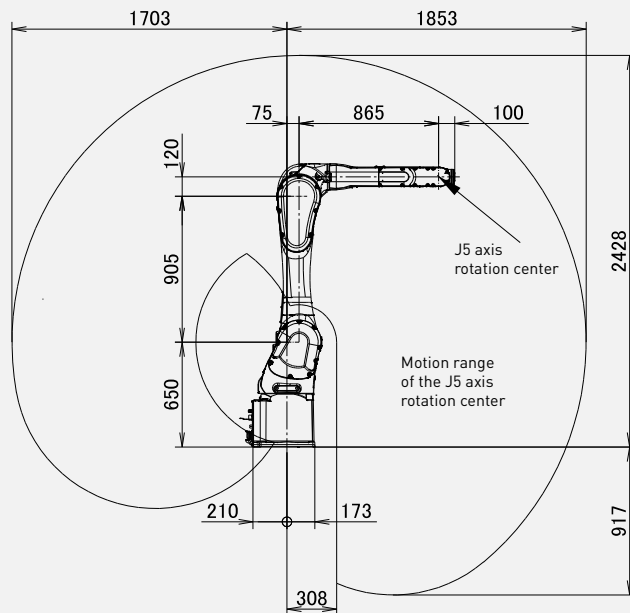
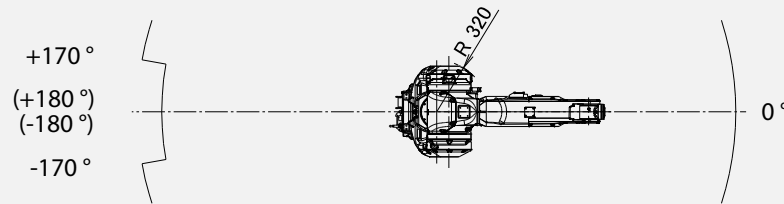

Robot

	M-20iB/25C
Robot footprint [mm]	383 x 343
Mounting position Floor	●
Mounting position Upside down	●
Mounting position Angle	●



Controller

	R-30iB Plus
Open air cabinet	-
Mate cabinet	○
A-cabinet	●
B-cabinet	○
iPendant Touch	●

Electrical connections

Voltage 50/60Hz 3phase [V]	380-575
Voltage 50/60Hz 1phase [V]	-
Average power consumption [kW]	1

Integrated services

Integrated signals on upper arm In/Out	8/2
Integrated air supply	1

Environment

Acoustic noise level [dB]	< 70
Ambient temperature [° C]	0-45

Protection

Body standard/optional	IP67
Wrist & J3 arm standard/optional	IP67

Air Cleanliness Class

Clean room class in accordance to ISO 14644-1	ISO class 5
---	-------------

● standard ○ on request - not available () with hardware and/or software option

*Based on ISO9283