

R-2000iC/210L (Long arm)



Max. load capacity
at wrist: **210 kg**



Max. reach:
3100 mm

Controlled axes	Repeatability (mm)	Mechanical weight (kg)	Motion range (°)						Maximum speed (°/s)						J4 Moment/ Inertia (Nm/kgm ²)	J5 Moment/ Inertia (Nm/kgm ²)	J6 Moment/ Inertia (Nm/kgm ²)
			J1	J2	J3	J4	J5	J6	J1	J2	J3	J4	J5	J6			
6	± 0.05*	1350	370	136	301	720	250	720	105	85	85	120	120	200	1700/320	1700/320	900/230

Working range

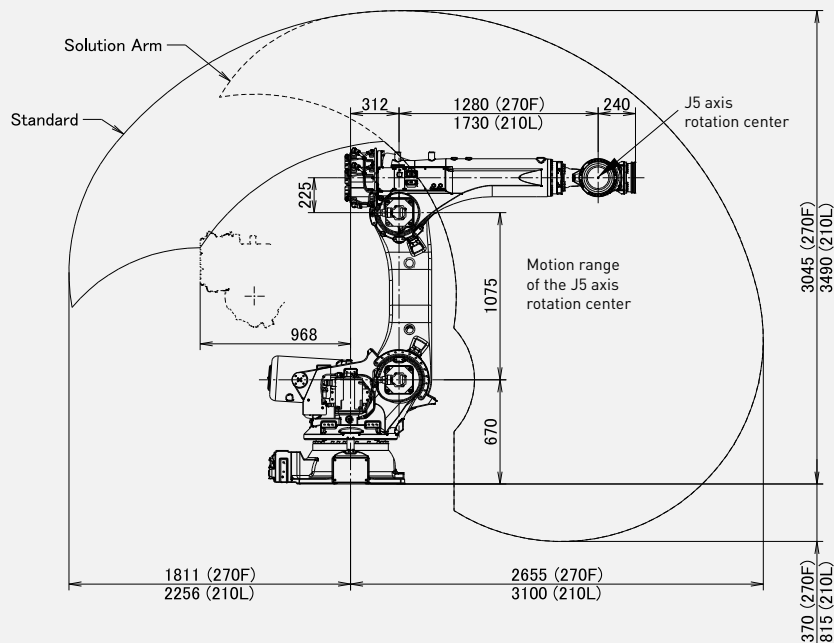
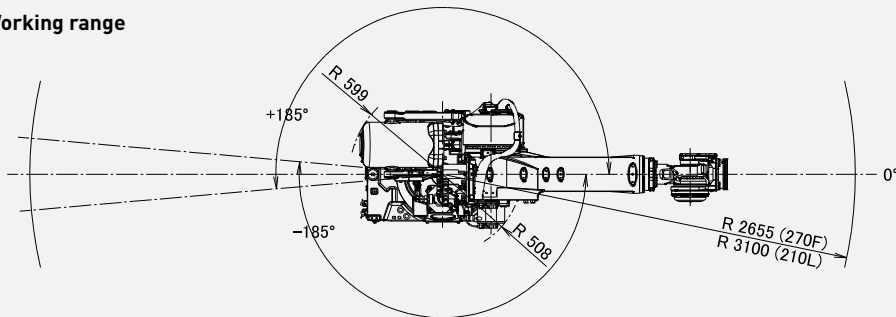

Robot

R-2000iC/210L

Robot footprint [mm]	771 X 610
Mounting position Floor	●
Mounting position Upside down	-
Mounting position Angle	-



Controller

R-30iB Plus

Open air cabinet	-
Mate cabinet	-
A-cabinet	●
B-cabinet	○
iPendant Touch	●

Electrical connections

Voltage 50/60Hz 3phase [V]	380-575
Voltage 50/60Hz 1phase [V]	-
Average power consumption [kW]	2.5

Integrated services

Integrated signals on upper arm In/Out	8/8
Integrated air supply	2

Environment

Acoustic noise level [dB]	70.5
Ambient temperature [° C]	0-45

Protection

Body standard/optional	IP54/IP56
Wrist & J3 arm standard/optional	IP67

● standard ○ on request - not available () with hardware and/or software option

*Based on ISO9283