

ARC Mate 120iD/35 (Hollow wrist)



Max. load capacity
at wrist: **35 kg**



Max. reach:
1831 mm

Controlled axes	Repeatability (mm)	Mechanical weight (kg)	Motion range [°]						Maximum speed [°/s]						J4 Moment/ Inertia (Nm/kgm ²)	J5 Moment/ Inertia (Nm/kgm ²)	J6 Moment/ Inertia (Nm/kgm ²)
			J1	J2	J3	J4	J5	J6	J1	J2	J3	J4	J5	J6			
6	± 0.03*	250	340 (370)	260	458	400	280 (360)*21)	540 (900)*21)	180	180	200	350	350	400	110.0/4.0	110.0/4.0	60.0/1.5

Working range

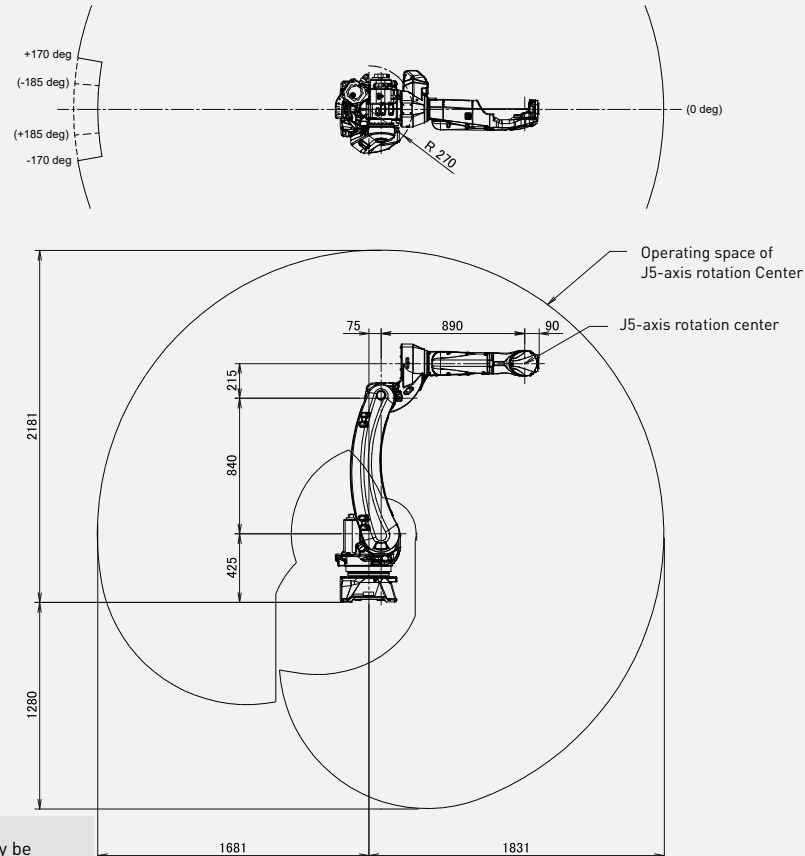

Motion range may be restricted according to the mounting angle!

Robot

	ARC Mate 120iD/35
Robot footprint [mm]	343 x 343
Mounting position Floor	●
Mounting position Upside down	●
Mounting position Angle	●

Controller

	R-30iB Plus
Open air cabinet	-
Mate cabinet	○
A-cabinet	○
B-cabinet	○
iPendant Touch	●

Electrical connections

Voltage 50/60Hz 3phase [V]	380-575
Voltage 50/60Hz 1phase [V]	-
Average power consumption [kW]	1

Integrated services

Integrated signals on upper arm In/Out	1/1
Integrated air supply	1

Environment

Acoustic noise level [dB]	< 70
Ambient temperature [° C]	0-45

Protection

Body standard/optional	IP54
Wrist & J3 arm standard/optional	IP67

*21) Extended range for external cable type

● standard ○ on request - not available () with hardware and/or software option

*Based on IS09283