

P-40iA



Max. load capacity
at wrist: **5 kg**



Max. reach:
1300 mm

Controlled axes	Repeatability (mm)	Mechanical weight (kg)	Motion range (°)						Maximum speed (°/s)						J4 Moment/ Inertia (Nm/kgm ²)	J5 Moment/ Inertia (Nm/kgm ²)	J6 Moment/ Inertia (Nm/kgm ²)
			J1	J2	J3	J4	J5	J6	J1	J2	J3	J4	J5	J6			
6	± 0.03	110	360	255	423	380	240	720	220	190	240	450	450	720	11.9/0.3	11.9/0.3	6.7/0.1

Working range

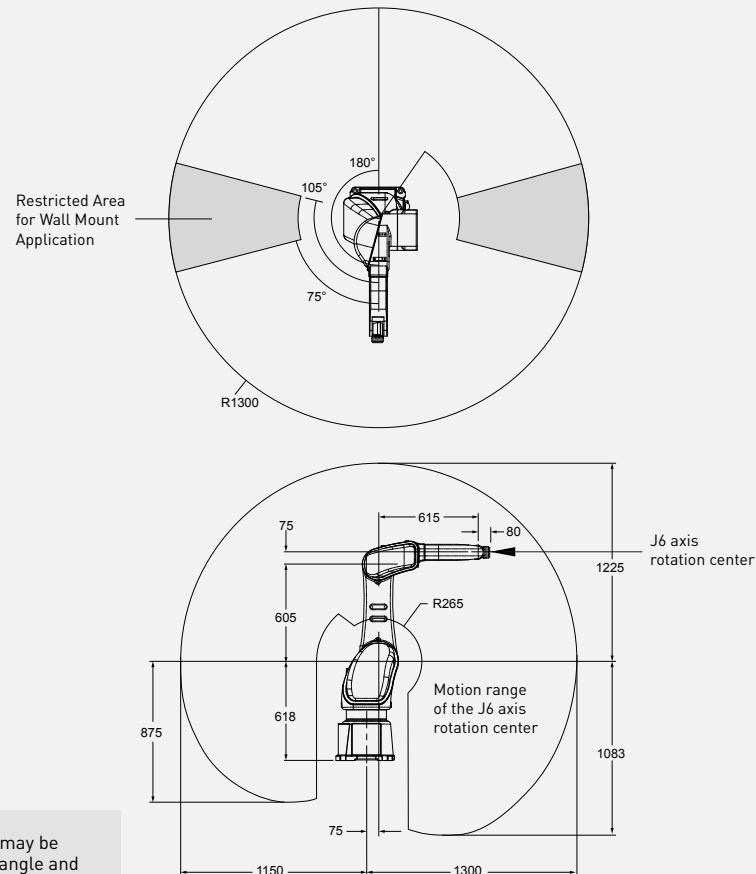

Motion range may be restricted for angle and wall mount!

Robot

	P-40iA
Robot footprint [mm]	340 x 355
Mounting position Floor	●
Mounting position Invert	●
Mounting position Wall	●
Mounting position Angle	●

Controller

	R-30iB Plus
Open air cabinet	-
Mate cabinet	●
A-cabinet	-
B-cabinet	-
iPendant	●
ISTP option	-

Electrical connections

Voltage 50/60Hz 3phase [V]	200-230
Voltage 50/60Hz 1phase [V]	-
Average power consumption [kW]	0.8

Integrated services

Integrated signals on upper arm In/Out	-
Integrated air supply	-

Environment

Acoustic noise level [dB]	-
Ambient temperature [° C]	0-45

Protection

Hazardous location certification	*5
----------------------------------	----

*5) ATEX certified Cat. II Group 2G and 2D

● standard ○ on request - not available () with hardware and/or software option