

# CR-35iB



Max. load capacity  
at wrist: **35/50 kg**



Max. reach:  
**1831/1643 mm**

Controlled axes	Repeatability (mm)	Mechanical weight (kg)	Motion range (°)						Maximum speed (mm/s)	J4 Moment/ Inertia (Nm/kgm <sup>2</sup> )	J5 Moment/ Inertia (Nm/kgm <sup>2</sup> )	J6 Moment/ Inertia (Nm/kgm <sup>2</sup> )
			J1	J2	J3	J4	J5	J6				
6	± 0.03*	386	370	215	338	400	280	900	750*2	110.0/4.00 (110.0/10.80)*3	110.0/4.00 (110.0/10.80)*3	60.0/1.50 (60.0/4.40)*3

## Working range

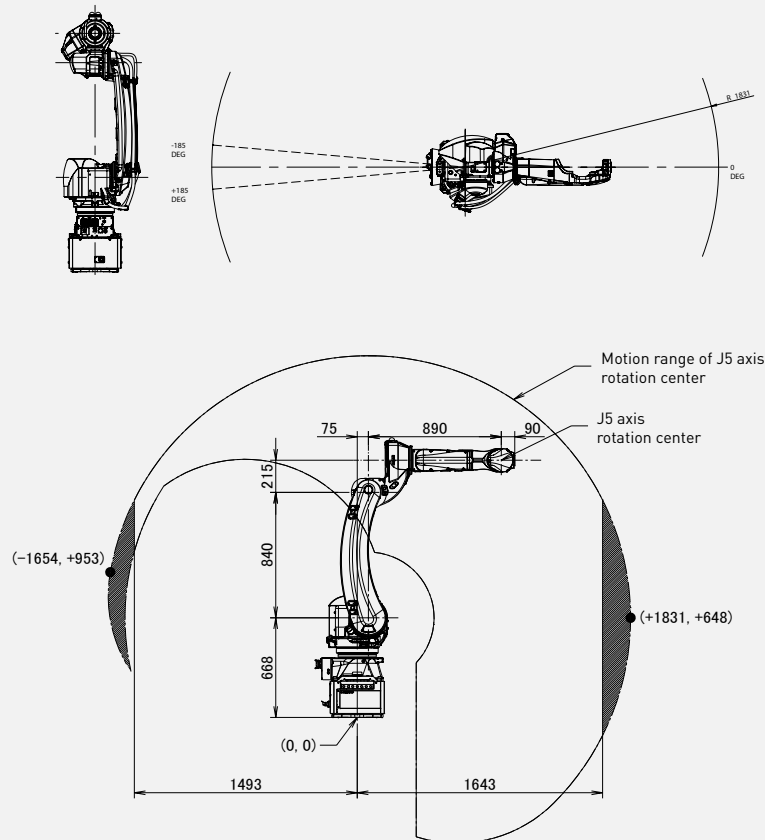

■ Max. reach is restricted from 1831 mm to 1643 mm in case of 50kg payload. No restrictions on wrist posture.



### Robot

Robot	CR-35iB
Robot footprint [mm]	300x300
Mounting position Floor	●
Mounting position Upside down	-
Mounting position Wall	-



### Controller

Controller	R-30iB Plus
Open air cabinet	-
Mate cabinet	-
A-cabinet	●
B-cabinet	-
iPendant Touch	●
Tablet TP	○

### Electrical connections

Voltage 50/60Hz 3phase [V]	380-575
Voltage 50/60Hz 1phase [V]	-
Average power consumption [kW]	1

### Integrated services

Integrated signals on upper arm In/Out	7/5
Integrated air supply	1

### Environment

Acoustic noise level [dB]	< 70
Ambient temperature [° C]	0-45

### Protection

Body standard/optional	IP54
Wrist & J3 arm standard/optional	IP67

\*1) In case of short distance motion, the speed may not reach the maximum value stated.

\*2) It is necessary to set a motion speed according to risk assessment of system considering pinching with the surroundings.

\*3) In case of 50 kg payload.

● standard ○ on request - not available ( ) with hardware and/or software option

\*Based on IS09283