

R-1000iA/130F



Max. load capacity
at wrist: **130 kg**



Max. reach:
2230 mm

| Controlled axes | Repeatability (mm) | Mechanical weight (kg) | Motion range (°) | | | | | | Maximum speed (°/s) | | | | | | J4 Moment/ Inertia (Nm/kgm ²) | J5 Moment/ Inertia (Nm/kgm ²) | J6 Moment/ Inertia (Nm/kgm ²) |
|-----------------|--------------------|------------------------|------------------|-----|-----|-----|-----|-----|---------------------|-----|-----|-----|-----|-----|---|---|---|
| | | | J1 | J2 | J3 | J4 | J5 | J6 | J1 | J2 | J3 | J4 | J5 | J6 | | | |
| 6 | ± 0.03* | 675 | 360 | 245 | 360 | 720 | 250 | 720 | 130 | 110 | 120 | 170 | 170 | 250 | 800/71 | 800/71 | 360/38 |

Working range

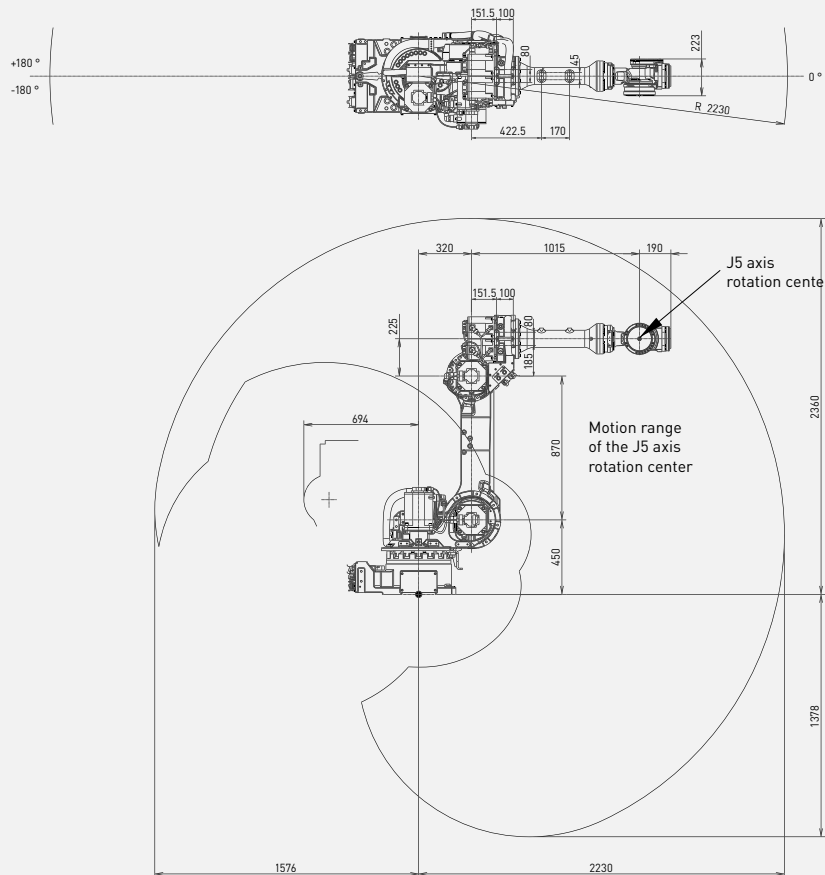

Robot

| | R-1000iA/130F |
|-------------------------------|---------------|
| Robot footprint [mm] | 605 X 450 |
| Mounting position Floor | ● |
| Mounting position Upside down | ● |
| Mounting position Angle | - |

Controller

| | R-30iB Plus |
|------------------|-------------|
| Open air cabinet | - |
| Mate cabinet | ○ |
| A-cabinet | ● |
| B-cabinet | ○ |
| iPendant Touch | ● |

Electrical connections

| | |
|--------------------------------|---------|
| Voltage 50/60Hz 3phase [V] | 380-575 |
| Voltage 50/60Hz 1phase [V] | - |
| Average power consumption [kW] | 3 |

Integrated services

| | |
|--|-----|
| Integrated signals on upper arm In/Out | 8/8 |
| Integrated air supply | 2 |

Environment

| | |
|---------------------------|------|
| Acoustic noise level [dB] | < 70 |
| Ambient temperature [° C] | 0-45 |

Protection

| | |
|----------------------------------|-----------|
| Body standard/optional | IP54/IP56 |
| Wrist & J3 arm standard/optional | IP67 |

● standard ○ on request - not available () with hardware and/or software option

*Based on ISO9283