

SR-12iA/C



Max. load capacity
at wrist: **12 kg**



Max. reach:
900 mm

Controlled axes	Repeatability (mm)	Mechanical weight (kg)	Motion range (°)						Maximum speed (°/s)						J4 Inertia (kgm ²)	J5 Inertia (kgm ²)	J6 Inertia (kgm ²)
			J1	J2	J3	J4	J5	J6	J1	J2	J3	J4	J5	J6			
4	±0.01 (J1,J2), ±0.01 (J3), ±0.005° (J4)	56	290	290	450/ 300mm*	1440/ endless ¹⁾	-	-	440	510	2800 mm/sec	2500	-	-	0.30	-	-

Working range

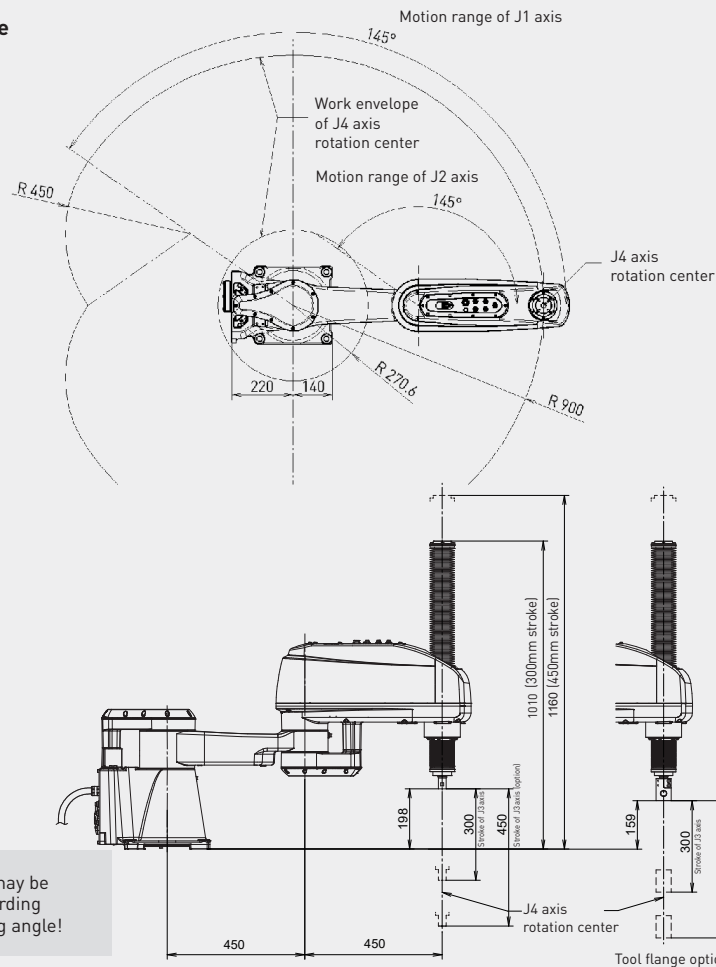

Motion range may be restricted according to the mounting angle!

Robot

Robot	SR-12iA/C
Robot footprint [mm]	280 x 360 (497)
Mounting position Floor	•
Mounting position Ceiling	-
Mounting position Angle	-
Mounting position Wall	•

Controller

Controller	R-30iB Plus
Compact Plus	•
iPendant Touch	○

Electrical connections

Voltage 50/60Hz 3phase [V]	-
Voltage 50/60Hz 1phase [V]	200-230
Average power consumption [kW]	0.5

Integrated services

Integrated signals on upper arm In/Out	4/4
Integrated air supply	2
Integrated solenoid valve	2

Environment

Acoustic noise level [dB]	<70
Ambient temperature [°C]	0-45

Protection

Body standard/optional	IP65
Wrist & J3 axis standard/optional	IP65
Cleanroom class (ISO Class 5)	•

Auxiliary

Max. push-down force (Newton)	250
-------------------------------	-----

Food grade / mechanical options

Food grade grease	•
White epoxy paint	•

1) Continuous rotation available as option

• standard ○ on request - not available [] with hardware and/or software option * optional