

SR-12iA



Max. load capacity
at wrist: **12 kg**



Max. reach:
900 mm

Controlled axes	Repeatability (mm)	Mechanical weight (kg)	Motion range (°)						Maximum speed (°/s)						J4 Inertia (kgm ²)	J5 Inertia (kgm ²)	J6 Inertia (kgm ²)
			J1	J2	J3	J4	J5	J6	J1	J2	J3	J4	J5	J6			
4	±0.015 (J1,J2), ±0.01 (J3), ±0.005° (J4)	53	290	290	450/ 300mm*	1440	-	-	440	510	2800 mm/sec	2500	-	-	0.30	-	-

Working range

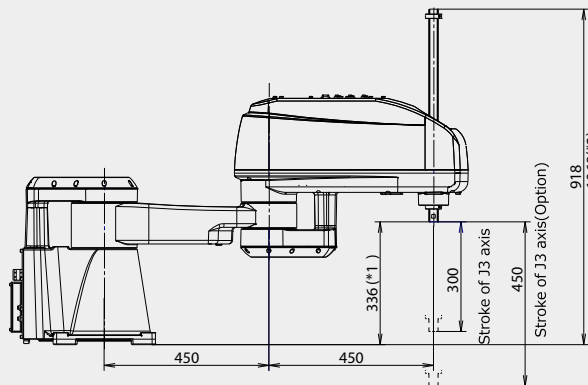
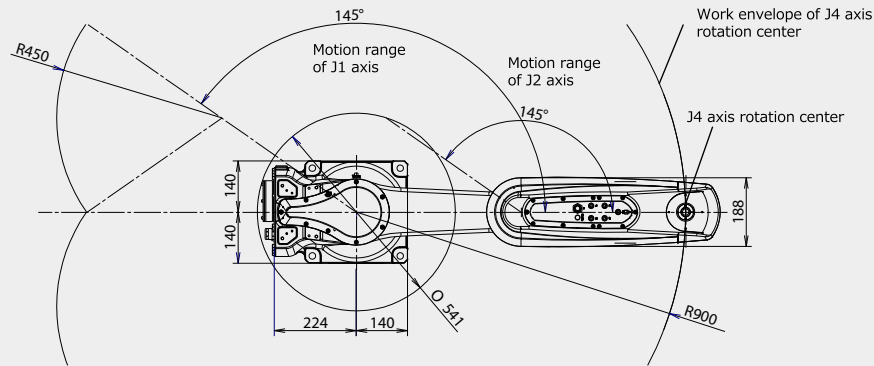

(*1) 198 for bellows option
(*2) 1175 for bellows option

Motion range may be restricted according to the mounting angle!

Robot

	SR-12iA
Robot footprint [mm]	280 x 360 (497)
Mounting position Floor	●
Mounting position Ceiling	-
Mounting position Angle	-
Mounting position Wall	○

Controller

	R-30iB Plus
Compact Plus	●
Open air cabinet	-
Mate cabinet	-
A-cabinet	-
B-cabinet	-
iPendant Touch	-

Electrical connections

Voltage 50/60Hz 3phase [V]	-
Voltage 50/60Hz 1phase [V]	200-230
Average power consumption [kW]	0.5

Integrated services

Integrated signals on upper arm In/Out	4 RI
Integrated air supply	1 x 6mm
Integrated solenoid valve	2 valves (4 RO)

Environment

Acoustic noise level [dB]	<70
Ambient temperature [°C]	0-45

Protection

Body standard/optional	IP20 \ IP65 *
Wrist & J3 arm standard/optional	IP20 \ IP65 *

Auxiliary

Max. push-down force (Newton)	250
Max. linear speed at TCP (mm/sec)	3000
Cleanliness class	[tbd]

● standard ○ on request - not available [] with hardware and/or software option * optional