

ARC Mate 100iD/10L (Hollow wrist)



Max. load capacity
at wrist: **10 kg**



Max. reach:
1636 mm

Controlled axes	Repeatability (mm)	Mechanical weight (kg)	Motion range (°)						Maximum speed (°/s)						J4 Moment/ Inertia (Nm/kgm ²)	J5 Moment/ Inertia (Nm/kgm ²)	J6 Moment/ Inertia (Nm/kgm ²)
			J1	J2	J3	J4	J5	J6	J1	J2	J3	J4	J5	J6			
6	± 0.03*	150	340 (370)	235	455	380	280 (360)*21)	540 (900)*21)	260	240	260	430	450	720	22.0/0.65	22.0/0.65	9.8/0.17

Working range

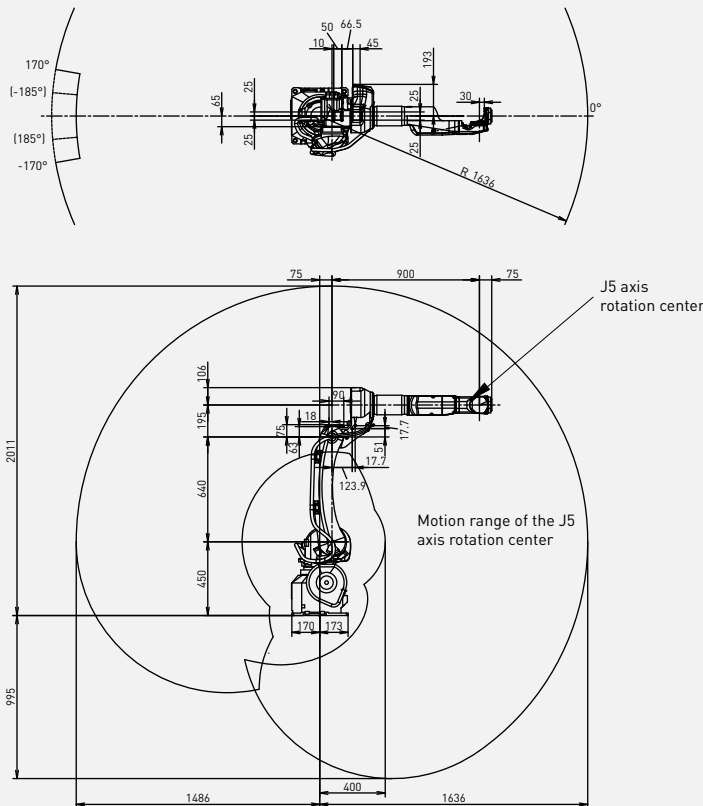

Motion range may be restricted according to the mounting angle!

Robot

Robot	ARC Mate 100iD/10L
Robot footprint [mm]	343 x 343
Mounting position Floor	●
Mounting position Upside down	●
Mounting position Angle	●

Controller

Controller	R-30iB Plus
Open air cabinet	-
Mate cabinet	○
A-cabinet	●
B-cabinet	○
iPendant Touch	●

Electrical connections

Voltage 50/60Hz 3phase [V]	380-575
Voltage 50/60Hz 1phase [V]	-
Average power consumption [kW]	1

Integrated services

Integrated signals on upper arm In/Out	1/1
Integrated air supply	1

Environment

Acoustic noise level [dB]	< 70
Ambient temperature [° C]	0-45

Protection

Body standard/optional	IP54
Wrist & J3 arm standard/optional	IP67

*21) Extended range for external cable type

● standard ○ on request - not available () with hardware and/or software option

*Based on IS09283