

P-350iA/45



Max. load capacity
at wrist: **45 kg**



Max. reach:
2606 mm

Controlled axes	Repeatability (mm)	Mechanical weight (kg)	Motion range [°]						Maximum speed [°/s]						J4 Moment/ Inertia (Nm/kgm ²)	J5 Moment/ Inertia (Nm/kgm ²)	J6 Moment/ Inertia (Nm/kgm ²)
			J1	J2	J3	J4	J5	J6	J1	J2	J3	J4	J5	J6			
6	± 0.06	590	360	225	440	800	250	800	180	180	180	250	250	300	206/28	206/28	127/20

Working range

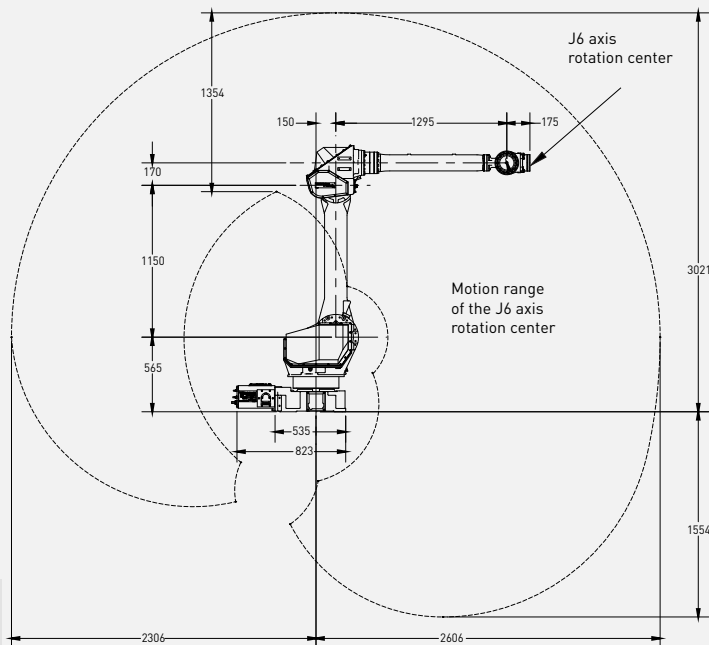
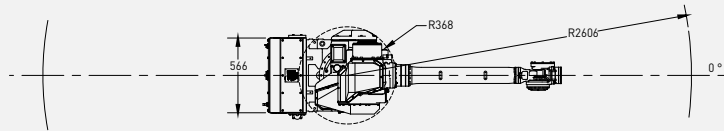

Maximum work envelope is restricted for mounting angles > 42°



Robot

	P-350iA/45
Robot footprint [mm]	827.5 x 642.3
Mounting position Floor	•
Mounting position Invert	•
Mounting position Wall	•
Mounting position Angle	•



Controller

	R-30iB Plus
Open air cabinet	-
Mate cabinet	-
A-cabinet	•
B-cabinet	-
iPendant	•
ISTP option	-

Electrical connections

Voltage 50/60Hz 3phase [V]	380-575
Voltage 50/60Hz 1phase [V]	-
Average power consumption [kW]	3.5

Integrated services

Integrated signals on upper arm In/Out	-
Integrated air supply	2

Environment

Acoustic noise level [dB]	71.3
Ambient temperature [° C]	0-45

Protection

Hazardous location certification	*5
----------------------------------	----

*5) ATEX certified Cat. II Group 2G and 2D

• standard ○ on request - not available () with hardware and/or software option