

M-1000iA



Max. load capacity
at wrist:
1000 kg



Max. reach:
3253 mm

Controlled axes	Repeatability (mm)	Mechanical weight (kg)	Motion range (°)						Maximum speed (°/s)						J4 Moment/ Inertia (Nm/kgm ²)	J5 Moment/ Inertia (Nm/kgm ²)	J6 Moment/ Inertia (Nm/kgm ²)
			J1	J2	J3	J4	J5	J6	J1	J2	J3	J4	J5	J6			
6	± 0.1	5300	330	145	260	720	240	720	60	50	50	70	70	85	8800/1750	8800/1750	5800/840

Working range

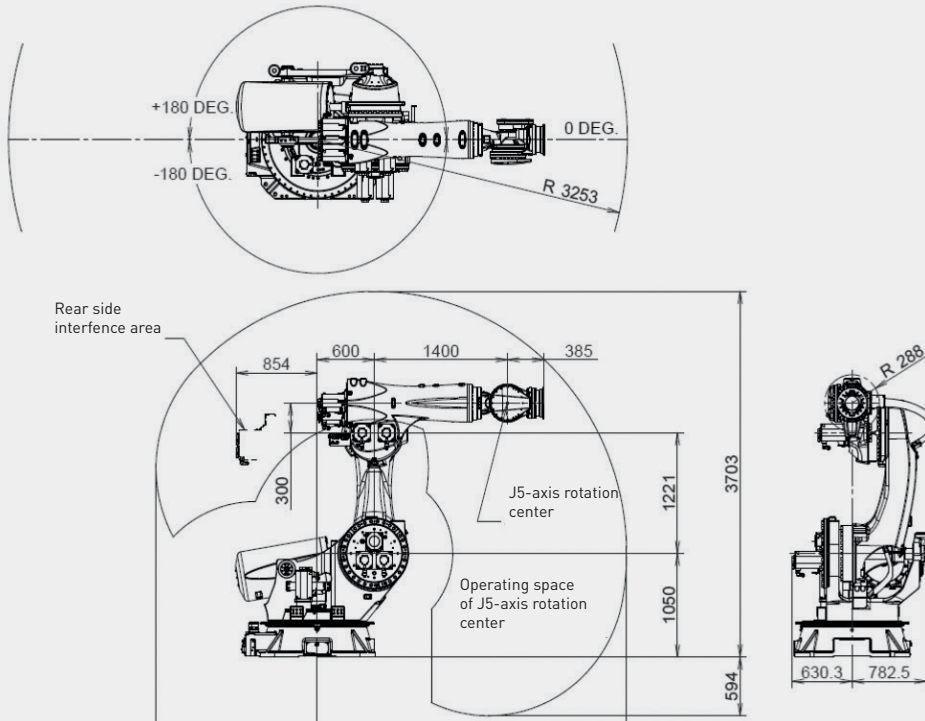

Robot

	M-1000iA
Robot footprint [mm]	1350 x 1210
Mounting position Floor	●
Mounting position Upside down	-
Mounting position Angle	-



Controller

	R-30iB Plus
Open air cabinet	-
Mate cabinet	-
A-cabinet	●
B-cabinet	○
iPendant Touch	●

Electrical connections

Voltage 50/60Hz 3phase [V]	●
Voltage 50/60Hz 1phase [V]	380-575
Average power consumption [kW]	8

Integrated services

Integrated signals on upper arm In/Out	8/8
Integrated air supply	2

Environment

Acoustic noise level [dB]	-
Ambient temperature [° C]	0-45

Protection

Body standard/optional	IP54
Wrist & J3 arm standard/optional	IP67

● standard ○ on request - not available () with hardware and/or software option